

REVISION HISTORY				
ZONE	REV	DESCRIPTION	DATE	APPROVED
	A	Added Notes, Opened up hole diameter	12/3/2009	
	B	Added drain holes, see sheets 2 and 6	12/14/2009	DAF

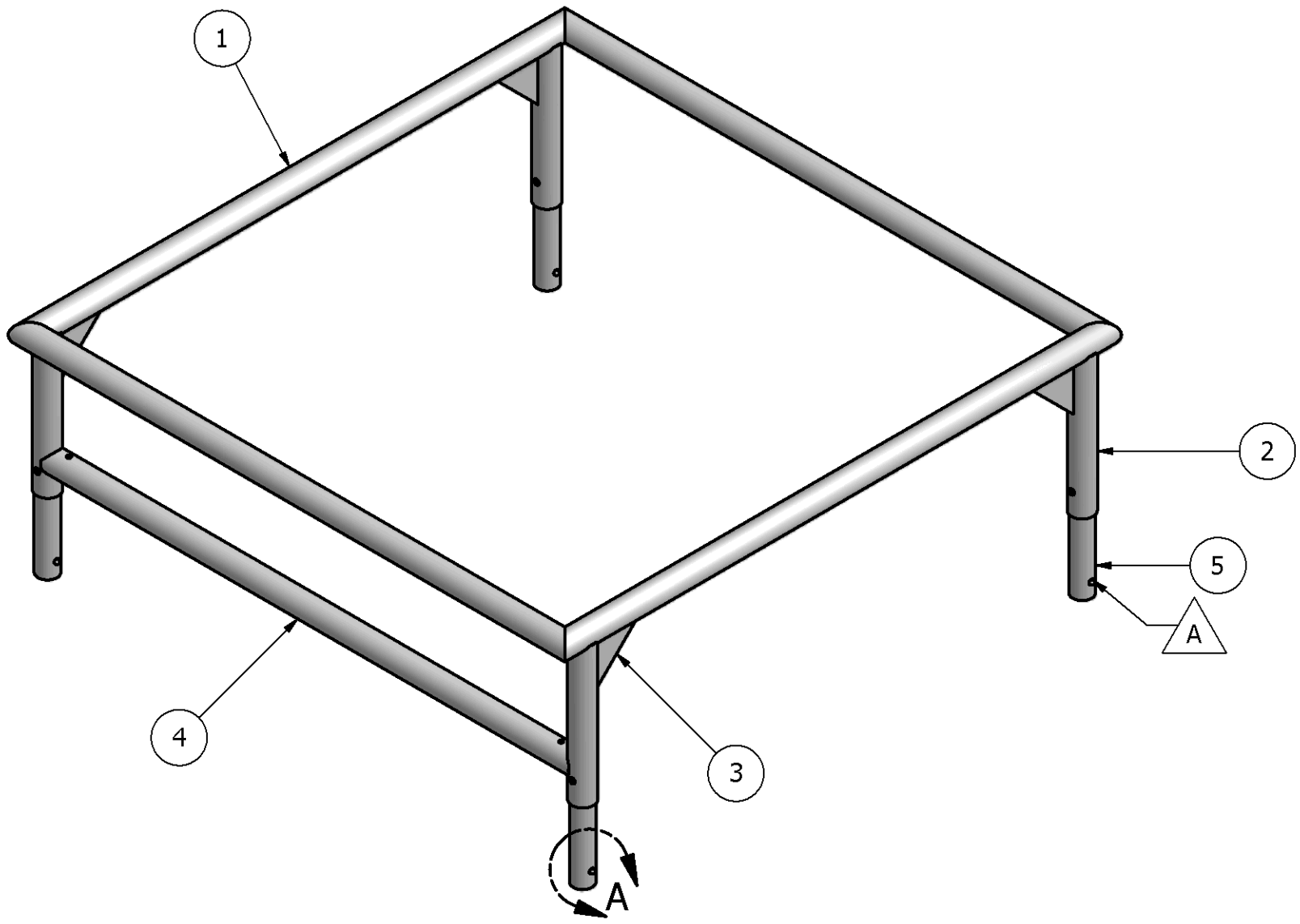

DETAIL A
SCALE 1 : 1

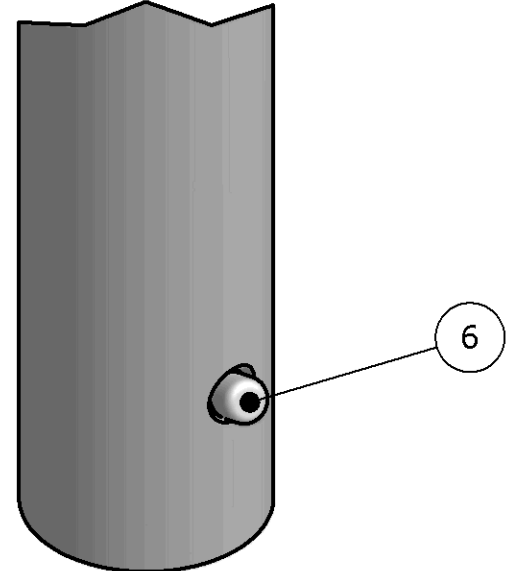

Resources		
Resource	Material	Quantity
1	1-1/2" x .083" Wall 1020 CRS DOM Tube	20 feet
2	3" x 1/2" Thick Steel Bar	15 inches
3	1-5/16" x .120" Wall 1020 CRS DOM Tube	42 inches
4	Quick release button	4 pcs

PARTS LIST			
ITEM	QTY	PART NUMBER	DESCRIPTION
1	4	GE-10028-01	Top Bar Side
2	4	GE-10028-02	Top Corner Down Simple
3	4	GE-10028-03	Corner Gussett
4	1	GE-10028-04	Support bottom
5	4	GE-10028-05	Insert
6	4	PP-00042	Quick Release Button 1-5/16" Tube OD

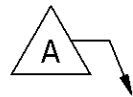

- Notes:
- 1.) To be free of burrs and sharp edges
 - 2.) Plating: zinc with clear chromate
 - 3.) Grainger part number for the quick release button 3DRA9

DRAWN mcyr	11/5/2009	FIRST 200 Bedford Street, Manchester, NH 03101 (603) 666-3906 -- FAX (603) 666-3907		
CHECKED				
UNLESS OTHERWISE SPECIFIED		TITLE Support		
TOLERANCES: (INCHES)				
FRAC.	+/- 1/32			
.00	+/- .01			
.000	+/- .005	SIZE B	DWG NO GE-10028	REV B
ANGULAR	+/- .25 Deg.	SCALE	SHEET 1 OF 6	

REVISION HISTORY				
ZONE	REV	DESCRIPTION	DATE	APPROVED
	A	See Sheet 1, opened up hole diameter	12/3/2009	
B-3	B	Added Drain Holes	12/14/2009	

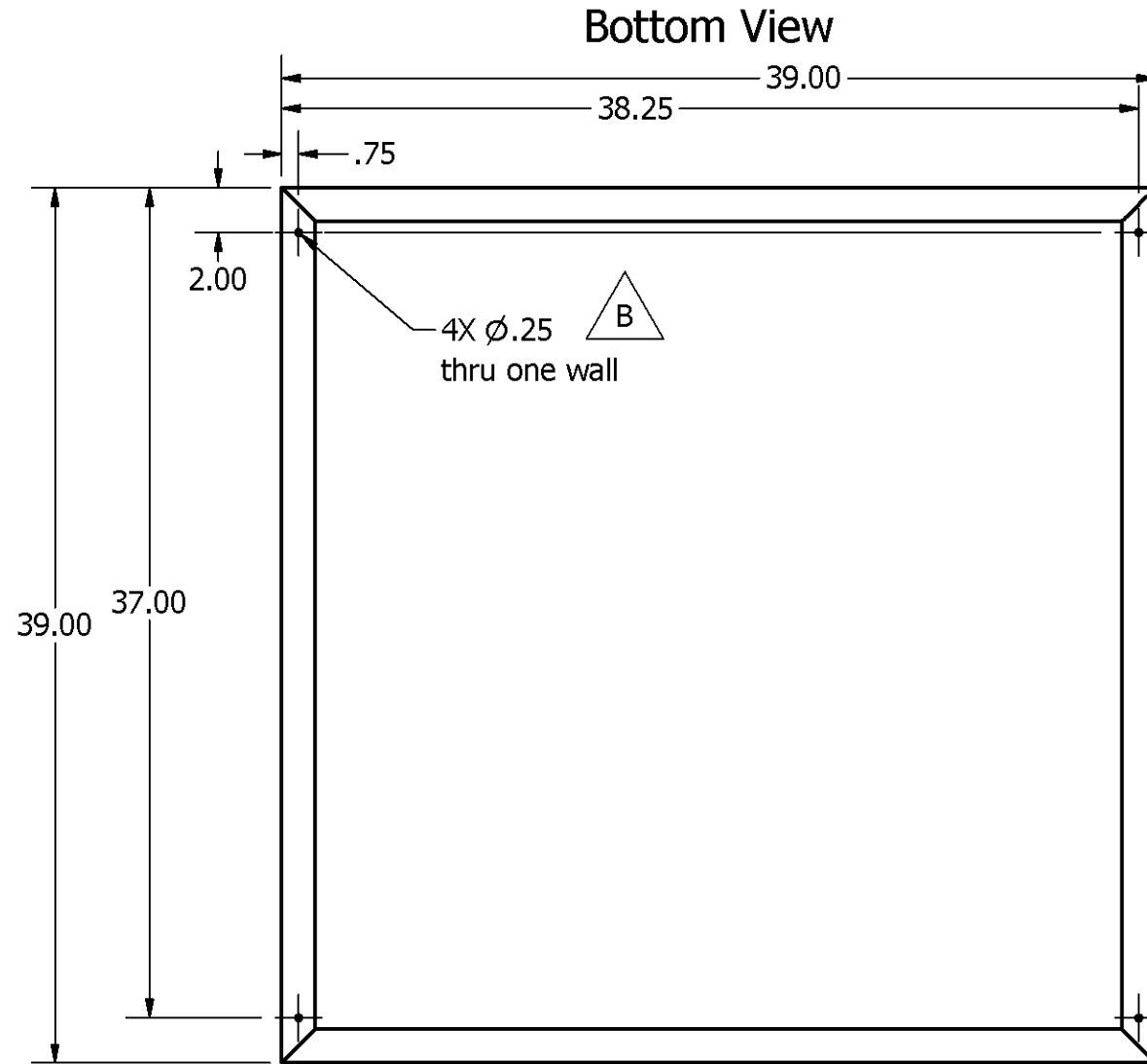

Side View



DRAWN mcyr	11/5/2009	<p align="center">FIRST</p> <p align="center">200 Bedford Street, Manchester, NH 03101 (603) 666-3906 -- FAX (603) 666-3907</p>		
CHECKED				
UNLESS OTHERWISE SPECIFIED		TITLE		
TOLERANCES: (INCHES)		Support		
FRAC.	+/- 1/32	SIZE	DWG NO	REV
.00	+/- .01	B	GE-10028	B
.000	+/- .005	SCALE	SHEET 2 OF 6	
ANGULAR	+/- .25 Deg.			

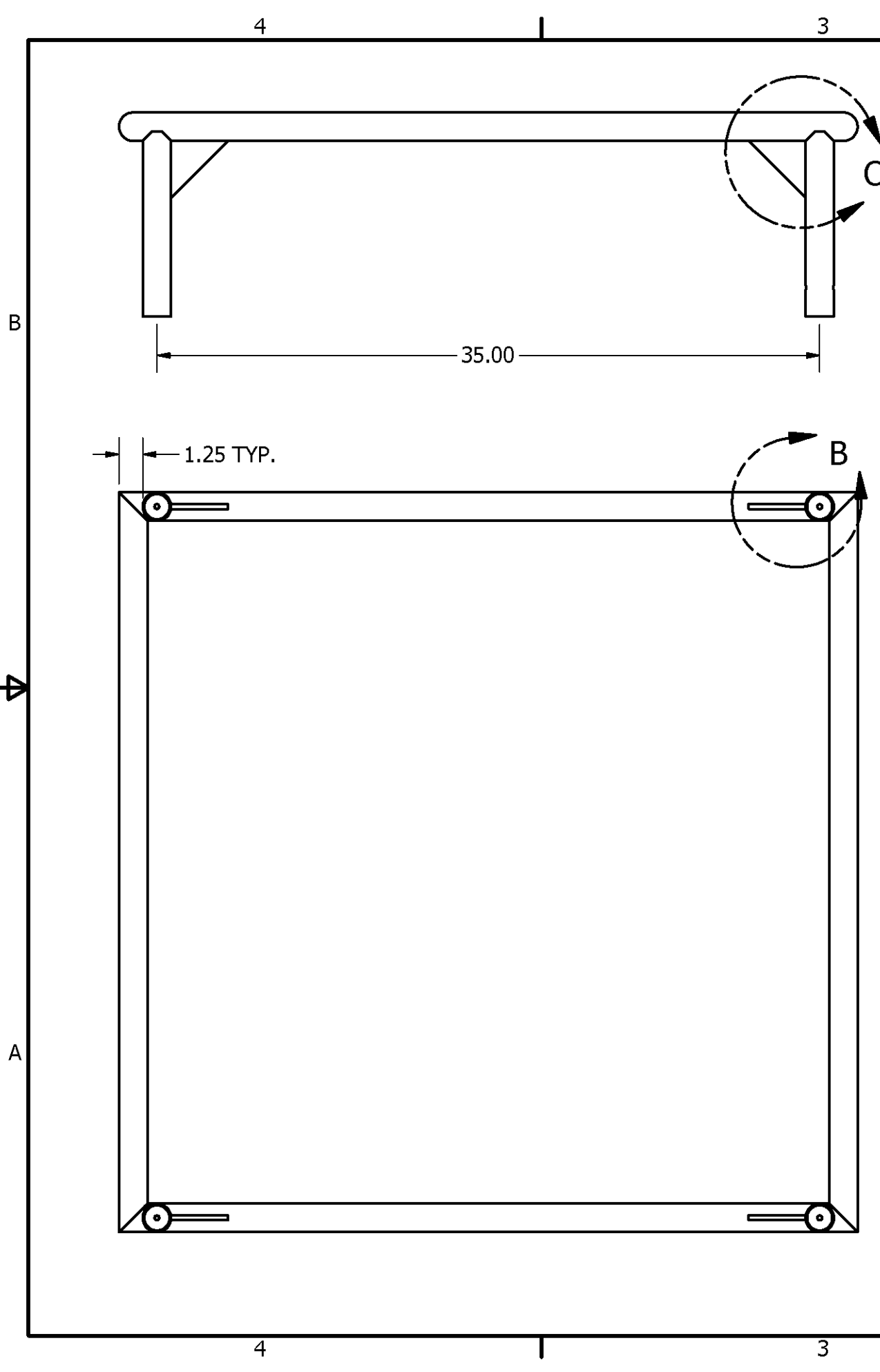

REVISION HISTORY				
ZONE	REV	DESCRIPTION	DATE	APPROVED
	A	See Sheet 1, opened up hole diameter	12/3/2009	
	B	See sheets 2 and 6	12/14/2009	DAF

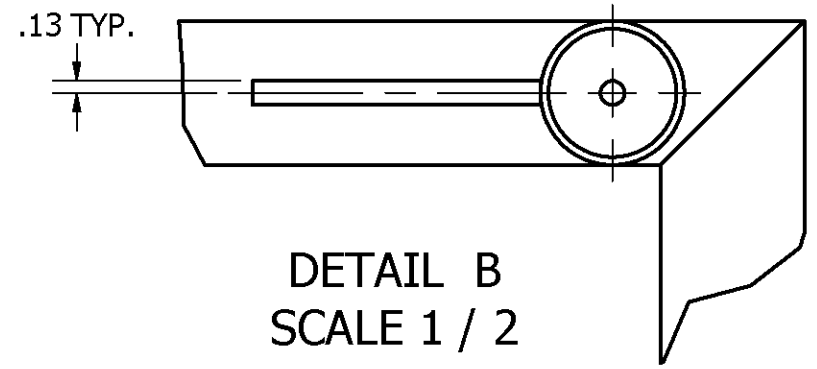
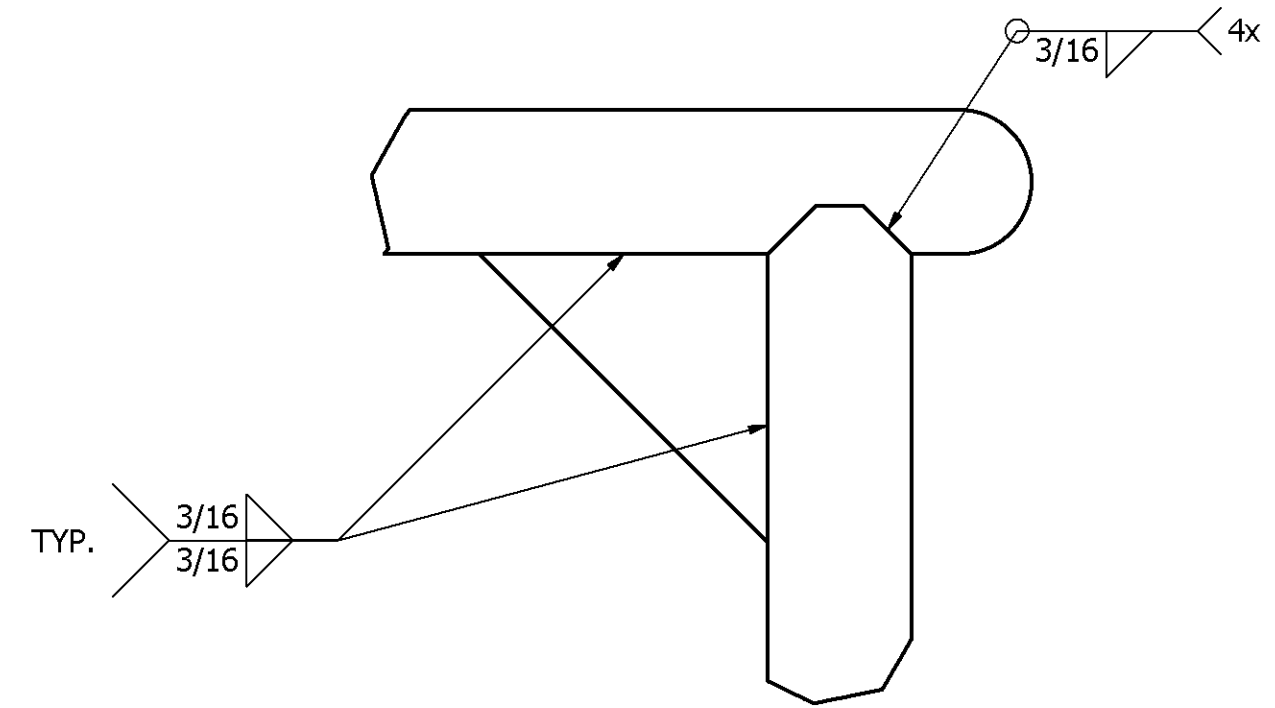

DETAIL C
SCALE 1 / 2

DRAWN mcyr	11/5/2009	FIRST 200 Bedford Street, Manchester, NH 03101 (603) 666-3906 -- FAX (603) 666-3907		
CHECKED				
UNLESS OTHERWISE SPECIFIED TOLERANCES: (INCHES)		TITLE Support		
FRAC.	+/- 1/32			
.00	+/- .01	SIZE B	DWG NO GE-10028	REV B
.000	+/- .005	SHEET 3 OF 6		
ANGULAR	+/- .25 Deg.			

REVISION HISTORY				
ZONE	REV	DESCRIPTION	DATE	APPROVED
	A	See Sheet 1, opened up hole diameter	12/3/2009	
	B	See Sheets 2 and 6	12/14/2009	DAF

Side

Front

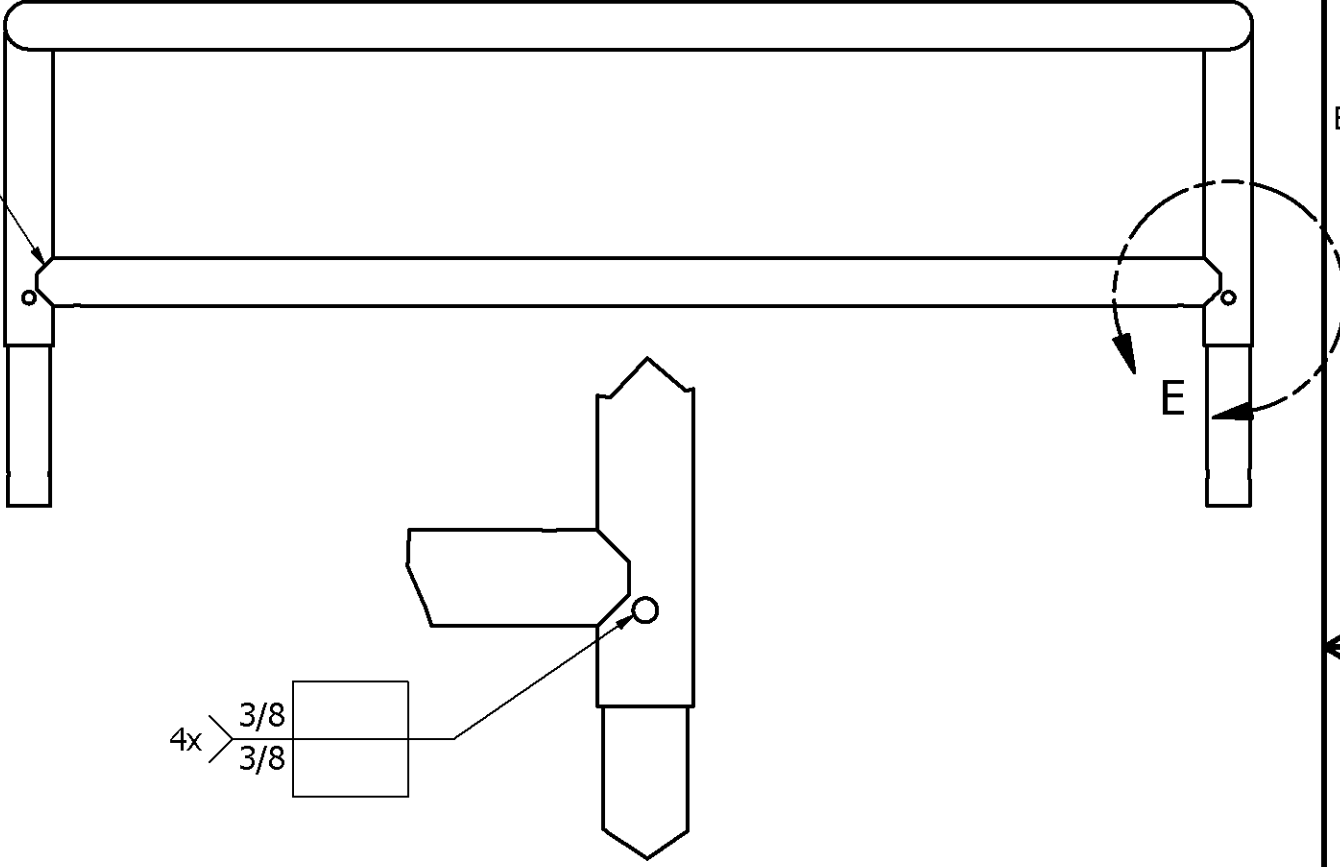
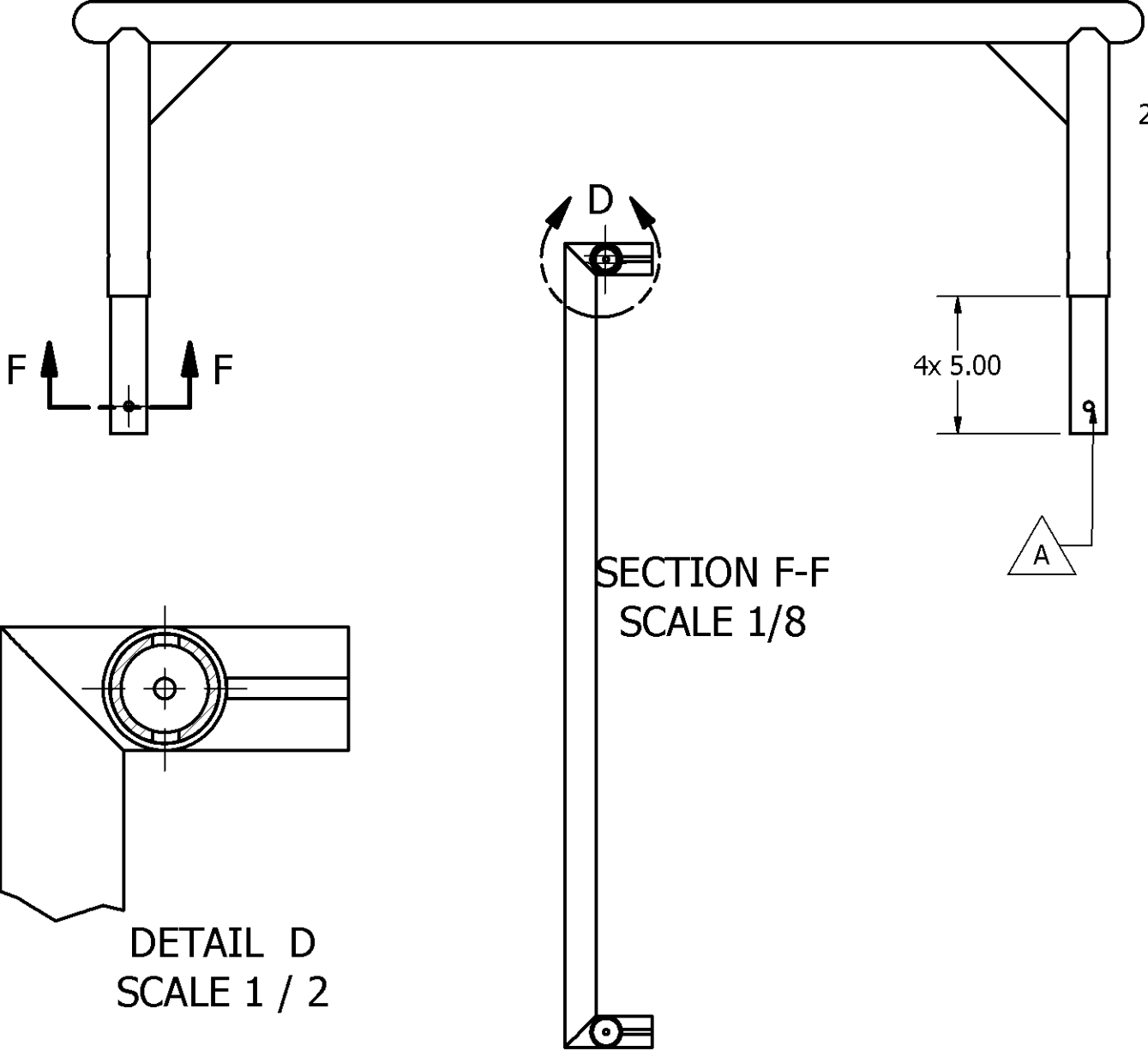

SECTION F-F
SCALE 1/8

DETAIL D
SCALE 1 / 2

DETAIL E
SCALE 1 / 3

Note:
Plug weld to be ground flush, no witness and free of burrs and sharp edges

DRAWN mcyr	11/5/2009	<p align="center">FIRST</p> <p align="center">200 Bedford Street, Manchester, NH 03101 (603) 666-3906 -- FAX (603) 666-3907</p>		
CHECKED				
UNLESS OTHERWISE SPECIFIED		TITLE		
TOLERANCES: (INCHES)		Support		
FRAC.	+/- 1/32	SIZE	DWG NO	REV
.00	+/- .01	B	GE-10028	B
.000	+/- .005	SCALE	SHEET 4 OF 6	
ANGULAR	+/- .25 Deg.			

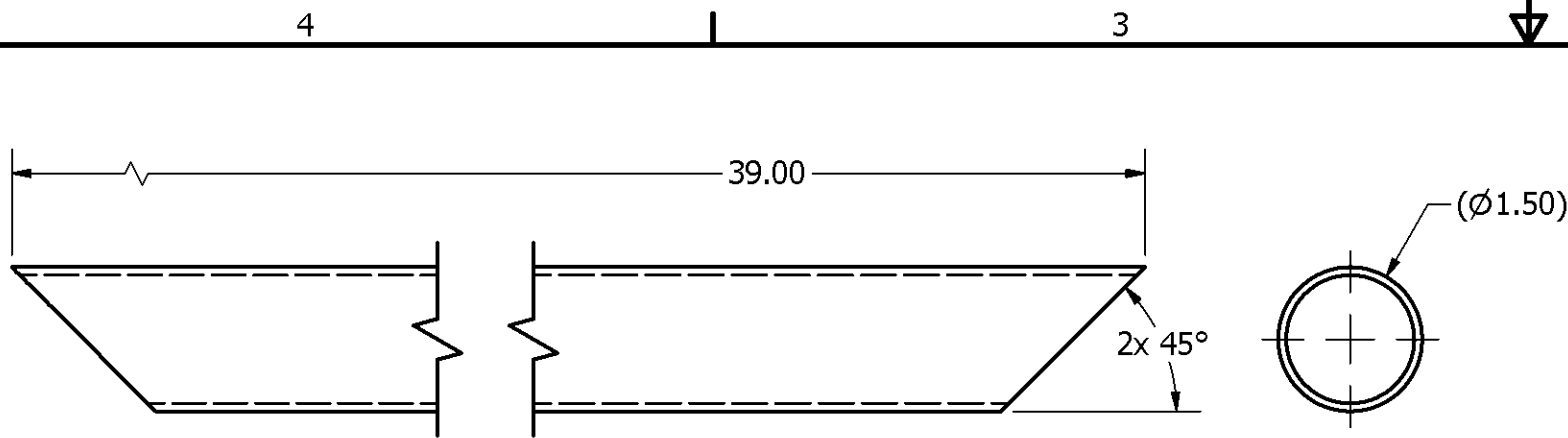

Item: 1, GE-10028-01, Top Bar Side
Resource: 1
Scale: 1/2
QTY: 4

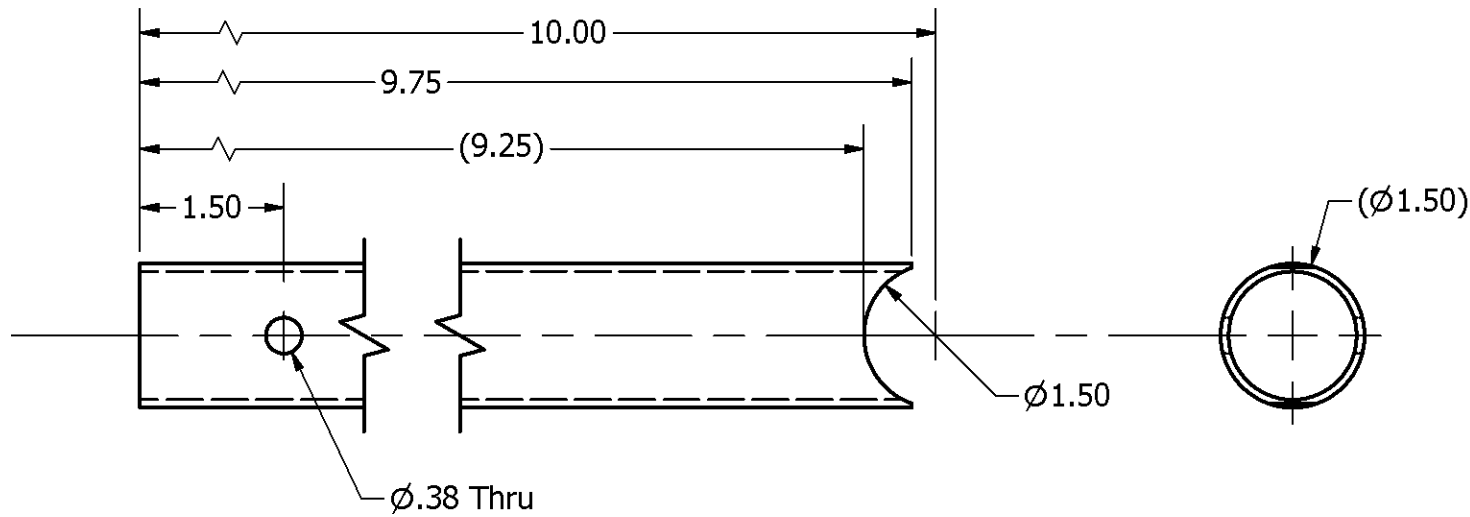

Item: 2, GE-10028-02, Top Corner Down Simple
Resource: 1
Scale: 1/2
QTY: 4

REVISION HISTORY				
ZONE	REV	DESCRIPTION	DATE	APPROVED
	A	See Sheet 1, opened up hole diameter	12/3/2009	
	B	See sheets 2 and 6	12/14/2009	DAF

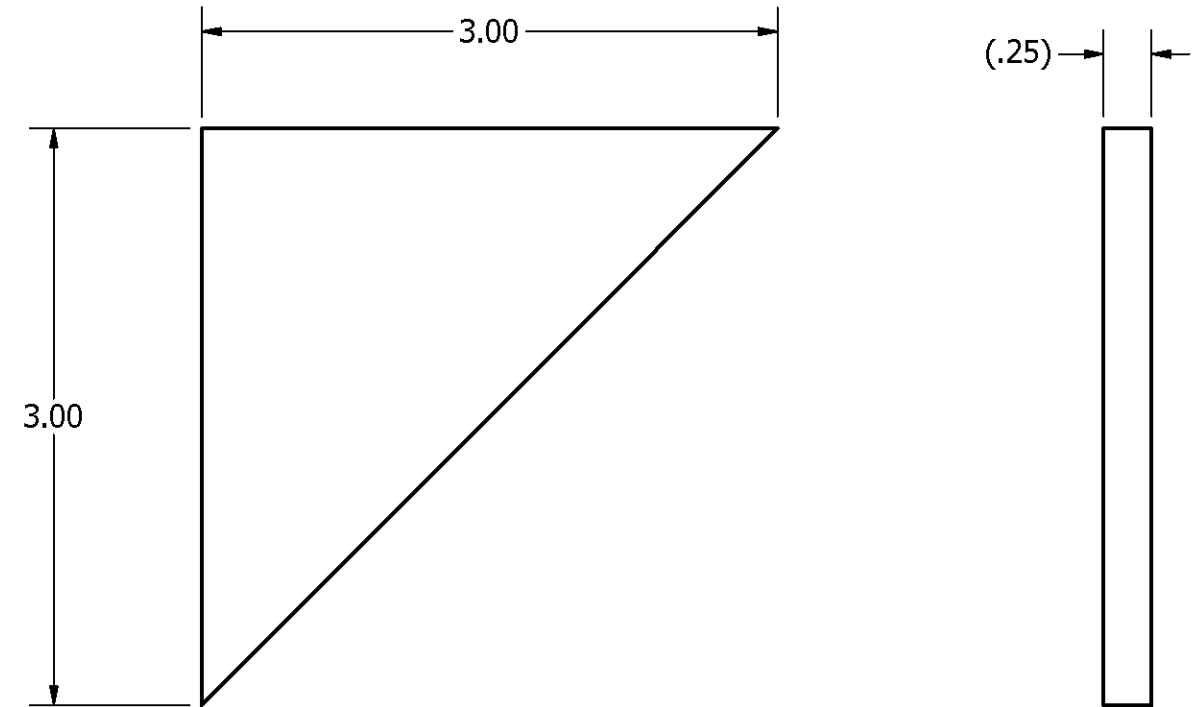

Item: 3, GE-10028-03, Corner Gusset
Resource: 2
Scale: 1:1
QTY: 4

DRAWN	mcyr	11/5/2009
CHECKED		
UNLESS OTHERWISE SPECIFIED		
TOLERANCES: (INCHES)		
FRAC.		+/- 1/32
.00		+/- .01
.000		+/- .005
ANGULAR		+/- .25 Deg.

FIRST		
200 Bedford Street, Manchester, NH 03101 (603) 666-3906 -- FAX (603) 666-3907		
TITLE Support		
SIZE	DWG NO	REV
B	GE-10028	B
SCALE	SHEET 5 OF 6	

REVISION HISTORY				
ZONE	REV	DESCRIPTION	DATE	APPROVED
	A	See Sheet 1, opened up hole diameter	12/3/2009	
B-2	B	Added drain holes to Item 4	12/14/2009	DAF

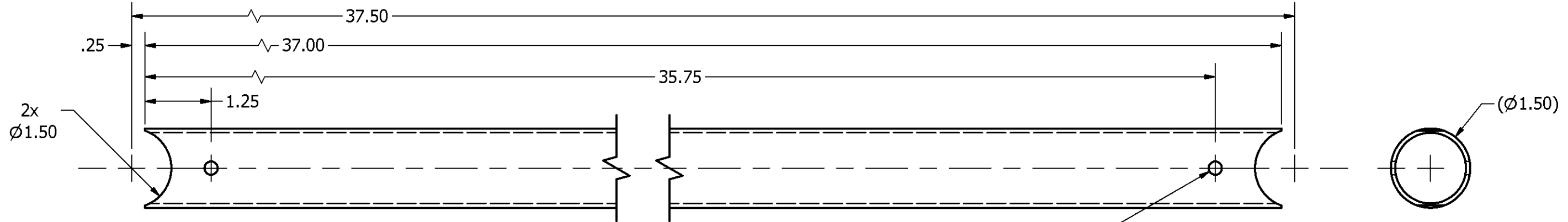

Item: 4, GE-10028-04, Support Bottom
Resource: 1
Scale: 1/2
QTY: 1

B 2X ϕ .25 thru

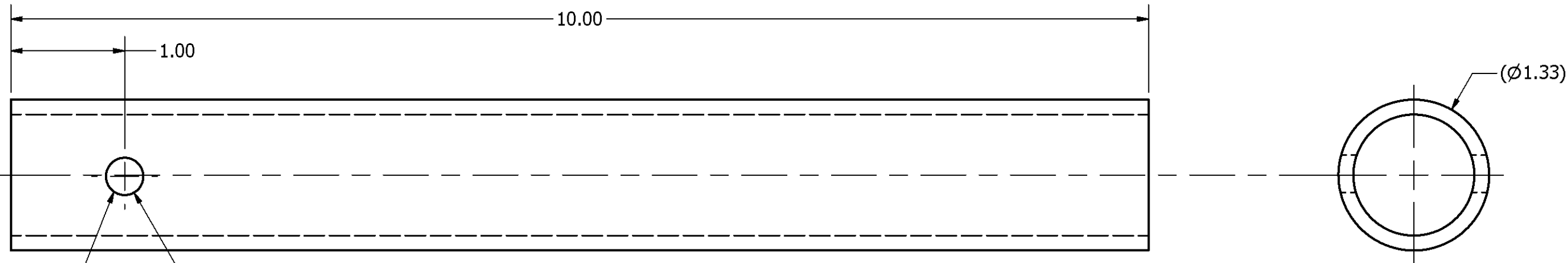

Item: 6, GE-10028-05, Insert
Resource: 3
Scale: 1:1
QTY: 4

A ϕ .328 Thru

DRAWN mcyr	11/5/2009	FIRST 200 Bedford Street, Manchester, NH 03101 (603) 666-3906 -- FAX (603) 666-3907		
CHECKED				
UNLESS OTHERWISE SPECIFIED		TITLE Support		
TOLERANCES: (INCHES)				
FRAC.	+/- 1/32			
.00	+/- .01			
.000	+/- .005	SIZE B	DWG NO GE-10028	REV B
ANGULAR	+/- .25 Deg.	SCALE	SHEET 6 OF 6	